

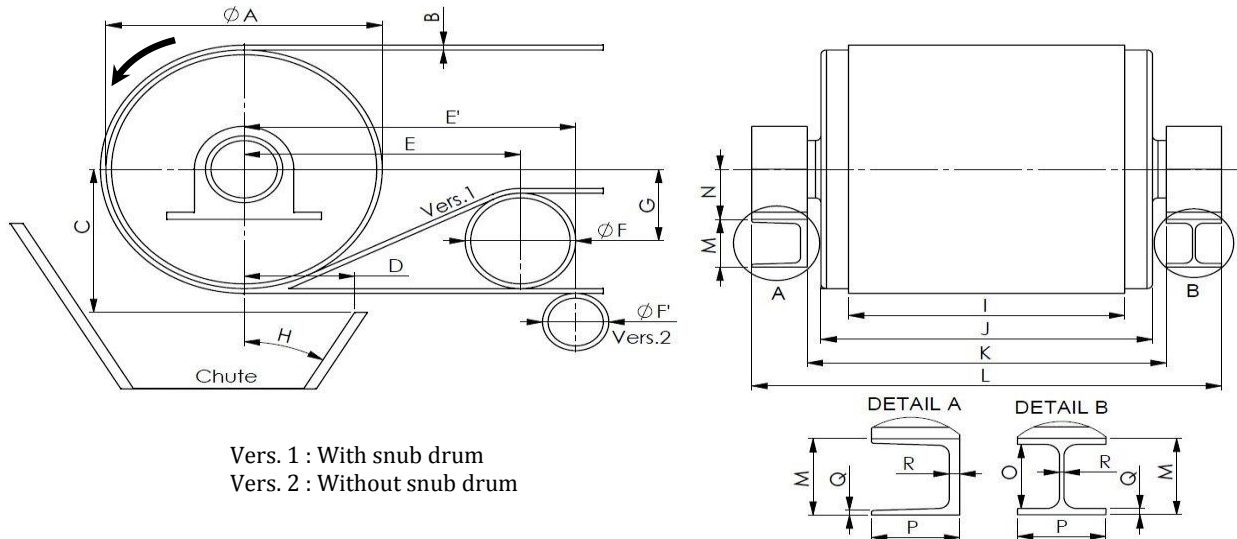

Drum handling specialist

TECHNICAL INDEX TO BE COMPLETED

| | |
|----------------------|--|
| Customer : | |
| Conveyor reference : | |



| | | |
|----------------------------|--|---|
| A | [mm] | ∅ |
| B | [mm] | |
| C | [mm] | |
| D | [mm] | |
| E/E' | [mm] | |
| F/F' | [mm] | ∅ |
| G | [mm] | |
| H | [°] | |
| I | [mm] | |
| J | [mm] | |
| K | [mm] | |
| L | [mm] | |
| DETAIL | | <input type="checkbox"/> A <input type="checkbox"/> B |
| M | [mm] | |
| N | [mm] | |
| O | [mm] | |
| P | [mm] | |
| Q | [mm] | |
| R | [mm] | |
| Position of roller vs belt | <input type="checkbox"/> Version 1 <input type="checkbox"/> Version 2 | |

| | | |
|-------------------------------------|--|---|
| Belt speed [m/s] | | |
| Belt condition | <input type="checkbox"/> Very well | <input type="checkbox"/> Well <input type="checkbox"/> Bad |
| Kind of belt condition | <input type="checkbox"/> Hot | <input type="checkbox"/> Cold <input type="checkbox"/> Mechanical |
| Reversible conveyor belt | <input type="checkbox"/> Yes <input type="checkbox"/> No | |
| Belt return run : motion in meters | <input type="checkbox"/> Yes meters | <input type="checkbox"/> No |
| Transported material description | | |
| Temperature of the transp. material | °C | |
| Area temperature | min. °C | max. °C |
| Drum convexity | <input type="checkbox"/> Curved | <input type="checkbox"/> Flat |
| Drum coat | <input type="checkbox"/> Rubber | <input type="checkbox"/> Ceramic |
| | <input type="checkbox"/> Other | |
| Note : | | |

If possible, please send us some photos !